



Crimped Fin Tube

The Crimped fin tubes also known as spirally tension wound finned tubes is a very widely used finned Tube type for a various number of applications.

As the name suggests the manufacturing of Crimped Finned Tube (Spiral Tension wound Fin Tube) is done by Tension winding of fin material on the base tube. The base tip of the fin strip is pre formed on a set of performing rollers.

This pre forming allows for a wider base and hence contact area is increased. It also enables more turbulence for the air flowing over the finned tube thereby increasing heat transfer efficiency. The ends of Fins are tag welded to secure its bond on the base.

This finning takes place on dedicated specially designed finning machines with auto feed mechanism. This process allows a very long length of tubes to be finned.

It finds application in various industries ranging from driers, radiators, heaters etc and are used in many industries like food, chemical, Oil Cooling etc.

Properties of Crimped Fin Tubes (Spiral Tension Wound Fin Tube):-

- Manufacturing Process:- Spirally Tension Wound (Crimped Fin Tube)
- Fin To Tube Bond:- Moderate
- Heat Transfer Efficiency:- Good
- Mechanical Resistance:- Very Good
- Corrosion Protection:- Moderate to very good (based on material properties of Fins & Tube)
- Temperature Range:- Upto Maximum 120 Deg C
- Crimped fin tube cross section (spiral tension wound fin tube cross section)

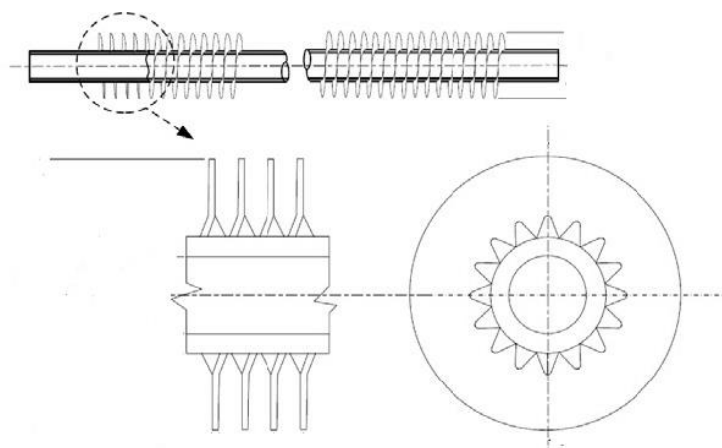

Crimped fin tube actual tubes supplied to the customer



Manufacturing Range (Crimped Fin Tube/Spiral Tension Wound Fin Tube):

Sr. No	Particulars	Range
1	Base Tube Material	Stainless Steel, Carbon Steel, Alloy Steel, Titanium, Copper, Duplex Stainless Steel, and Inconel etc. (all material in the theoretical limit)
2	Base Tube Outside Diameter	15.88 mm to 219.00 mm OD ($\frac{3}{8}$ " NB pipe to 8" NB pm)
3	Base Tube Thickness	1.00 mm And Above
4	Base Tube Length	500 mm Min To 15000 mm
5	Fin Material	Aluminum, Copper, Stainless Steel, Carbon Steel.
6	Fin Thickness	0.15mm, 2.00mm
7	Fin Density	118 FPM (3 FPI) to 433 FPM (11 FPI)
8	Fin Height	6 mm to 25.40 mm
9	Bare Ends	As per Client Requirement
10	Manufacturing Capacity	4,00,000 Meter Per Annum

We can supply material on an urgent delivery basis because of large stock and relations with raw material suppliers. We use only Prime Quality base tube and Fin Material.

Note:

The Crimped Fin Tubes (Spiral Tension Wound Fin Tube) can be supplied with EN 10204 EN 3.1 and EN 3.2 certifications. We can provide Third Party Inspection from any reputed inspection agency.

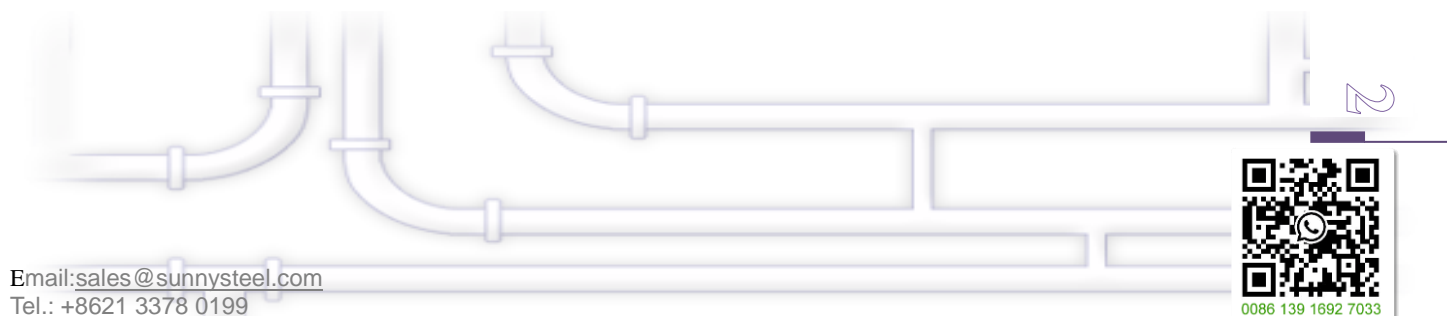



--- www.sunnysteel.com ---

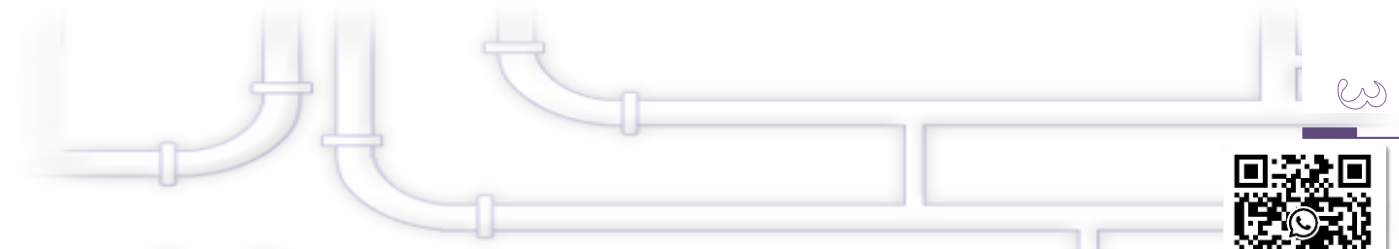

Email: sales@sunnysteel.com
Tel.: +8621 3378 0199



0086 139 1692 7033